



Tron SART20





www.jotron.com

EC Declaration of Conformity, available at www.jotron.com

Abbreviations and definitions

EMC

Electromagnetic Compatibility

LED

Light Emitting Diode

SART

Search and Rescue Transponder

VHF

Very High Frequency



Amendment Records

AMEND- MENT NO.	INCORP. BY	DATE	PAGE(S)	VERSION	REASON FOR CHANGE
1	ES	14.09.07	Total: 24	A	New product
2	ES	02.04.08	10, 15	B	Added text
3	ES	29.07.08	1	C	Background
4	ES	04.08.08	15,16	D	Lifeboat bracket updated
5	ES	14.08.08	9,13,21	E	Battery label
6	TH	12.02.09	10, 13-19, new tot. 28	F	Brackets and layout
7	ES	16.12.09	24	G	Added text
8	FIT	05.11.10	24-25	H	Added information
9	TH	01.02.11	15	I	New pics on figure 4.1.2b and 4.1.3
10	TH	14.04.2011	Total 28	J	Updated information



www.jotron.com

The information in this book has been carefully checked and is believed to be accurate. However, no responsibility is assumed for inaccuracies.



CAUTION!

This equipment contains CMOS integrated circuits. Observe handling precautions to avoid static discharges which may damage these devices. Jotron AS reserves the right to make changes without further notice to any products or modules described herein to improve reliability, function or design. Jotron AS does not assume any liability arising out of the application or use of the described product.

WARNING / IMPORTANT

Jotron AS is a prime manufacturer of safety equipment designed for rescue of human lives and their property. For safety equipment to be effective in line with the design parameters it is important that they are handled, stowed and maintained in compliance with the manufacturers instructions. Jotron AS cannot be held responsible for any damage caused due to incorrect use of the equipment or breach of laid down procedures or for failure of any specific component or other parts of the equipment.

The chapter covering battery replacement (6.2.1) is added for information only. Jotron AS does not take any responsibility for improper disassembling/ assembling of the beacon. We strongly recommend all service to be done by authorized Jotron agents. In addition to normal service, Jotron agents have the necessary equipment and knowledge to test the operational functions of the beacon. Non-original maintenance and/or service parts may destroy the equipment function and performance.



Table of contents

1	GMDSS Requirements	7
1.1	General description	8
1.2	Tron SART20 features	9
2	Technical specifications	10
2.1	Electrical specifications	10
2.2	Mechanical specification	10
3	Functional description	11
3.1	General	11
3.1.1	Tron SART20 electronic assembly	11
3.1.2	Battery module	12
3.1.3	Bottom lid	12
4	Installation	13
4.1	Brackets	13
4.1.1	Wall bracket	13
4.1.2	Lifeboat bracket (optional)	14
4.1.3	Using the telescopic pole	16
5	Operation	17
5.1	Activating Tron SART20	17
5.1.1	Deactivating Tron SART20	17
5.2	Usage in lifeboat/life raft	17
5.2.1	SART pocket	18
5.2.2	Life raft mounting strap	18
5.2.3	SART pole mounting	18
5.2.4	10 m rope slide	19
5.3	Test of Tron SART20	21
6	Maintenance and troubleshooting	23
6.1	Maintenance	23
6.2	Service	23
6.2.1	Replacing the battery module	24
6.2.2	Battery disposal	26
6.2.3	Incineration	26
6.2.4	Land filling	26
6.2.5	Recycling	26
7	Spare parts/Accessories	26
8	Service agents	27



www.jotron.com

Battery safety data sheet

(Form: EEC directive 91/155)

(2) SAFETY ADVICE

- S2 Keep out of reach of children.
- S8 Keep container dry.
- S26 In case of contact with eyes, rinse immediately with plenty of water and seek medical advice.
- S43 In case of fire, use D type extinguishers. Never use water.
- S45 In case of accident or if you feel unwell, seek medical advice immediately (show the label where possible).

(3) FIRST AID MEASURES

In case of contact of cell contents with eyes, flush immediately with water for 15 min. With skin, wash with plenty of water and take off contaminated clothes. If inhaled, remove from exposure, give oxygen, and seek medical advice.

(4) FIRE-FIGHTING MEASURES

Extinguishing media

Suitable: Type D fire extinguishers

Not to be used: Water - CO₂ - Halon, dry chemical or foam extinguishers

Special exposure hazards

Generation of chlorine, sulphur dioxide, disulphur dichloride during thermal decomposition.

Special protective equipment

Use protective working boots, rubber apron and safety glasses with side shields.



1 GMDSS REQUIREMENTS

Jotron GMDSS products are manufactured and approved to be compliant with relevant IMO/ SOLAS (Safety of Life at Sea) Regulations and requirements. The SOLAS GMDSS regulations are structured such that all GMDSS ships are required to carry a minimum set of equipment, with (basically) more equipment being required the further the ship travels from land. GMDSS requirement for SART (Search and Rescue Locating Device) according to SOLAS :

Chapter III, Regulation 6

2.2 Search and rescue locating devices

At least one search and rescue locating device shall be carried on each side of every passenger ship and of every cargo ship of 500 gross tonnage and upwards. At least one search and rescue locating device shall be carried on every cargo ship of 300 gross tonnage and upwards but less than 500 gross tonnage. Such search and rescue locating devices shall conform to the applicable performance standards not inferior to those adopted by the Organization*. The search and rescue locating devices** shall be stowed in such location that they can be rapidly placed in any survival craft other than the liferaft or liferafts required by regulation 31.1.4. Alternatively one search and rescue locating device shall be stowed in each survival craft other than those required by regulation 31.1.4. On ships carrying at least two search and rescue locating devices and equipped with free-fall lifeboats one of the search and rescue locating devices shall be stowed in a free-fall lifeboat and the other located in the immediate vicinity of the navigation bridge so that it can be utilized on board and ready for transfer to any of the other survival craft.

* Refer to the Recommendation on performance standards for survival craft radar transponders for use in search and rescue operations, adopted by the Organization by resolution MSC.247(83) (A.802(19)), as amended) and the Recommendation on performance standards for survival craft AIS Search and Rescue transmitter (AIS SART), adopted by the Organization by resolution MSC.246(83).

** One of these search and rescue locating devices may be the search and rescue locating device required by regulation IV/7.1.3.

Regulation 26 - Additional requirements for ro-ro passenger ships

2 Liferrafts

2.5 Liferrafts carried on ro-ro passenger ships shall be fitted with a search and rescue locating device in the ratio of one search and rescue locating device for every four liferafts. The search and rescue locating device shall be mounted inside the liferaft so its antenna is more than one metre above the sea level when the liferaft is deployed, except that for canopied reversible liferafts the search and rescue locating device shall be so arranged as to be readily accessed and erected by survivors. Each search and rescue locating device shall be arranged to be manually erected when the liferaft is deployed. Containers of liferafts fitted with search and rescue locating devices shall be clearly marked."

Chapter IV, Regulation 7- Radio Equipment- General

1 Every ship shall be provided with:

.3 A search and rescue locating device capable of operating either in the 9 GHz band or on frequencies dedicated for AIS, which:

.3.1 shall be so stowed that it can be easily utilized; and

.3.2 may be one of those required by reg. III/6.2.2 for a survival craft

Tron SART20 is also compliant with relevant sections in these regulations/requirements:

- SOLAS 74 as amended, Regulation III/6.2.2, IV/7.1.3, IMO Res. MSC.97 (73) 14.7.1.3, MSC.247(83), IMO Res. A.530 (13), IMO Res. A.802 (19), IMO Res. A.694 (17), ITU-R M.628-3 (11/93), IEC 61097-1:1992, IEC 61097-1(2007), IEC 60945:1996 and IEC 60945 ed.4:2002
- IMO Resolutions MSC.256(84)
- COMSAR/Circ.32
- European Directive 2009/26/EC
- Other national certifications/requirements



1.1 GENERAL DESCRIPTION

Tron SART20 is emergency equipment consisting of:

1. Tron SART20 radar transponder.
2. Mounting rope for life rafts / life boats.

The 9 GHz radar transponder type Tron SART20 is developed by Jotron AS to meet the rules and regulations for use on vessels and life rafts in the maritime service. Tron SART20 meets the specifications for 9 GHz radar transponders for use in search and rescue operations at sea.

The operating range of the Tron SART20 is up to 30 nautical miles, depending on the height of the electronic unit and the radar height of the search and rescue unit (sea or airborne). With a radar height of 20m and the Tron SART20 placed at 1m above sea level, the range will be up to 10 nautical miles. Tron SART20 is buoyant, however to obtain maximum performance the transponder should be placed in a vertical position and as high up as possible in order to achieve maximum coverage. Several mounting brackets and mounting aids are available to ensure correct mounting and use of the radar transponder.

The purpose of the Tron SART20 is to perform a secondary alarm when search and rescue units are searching for a life raft / lifeboat in distress. The Tron SART20 will help the units to pinpoint exactly where the distressed boat is located in a larger area. This is done with the help of the radar on the searching ship or helicopter.

When the Tron SART20 is interrogated (hit) by a radar signal, it will immediately start to transmit a number of sweeps covering the complete maritime 3 cm radar band. These sweeps are detected on the radar screen and are used to navigate directly towards the distressed life raft, for details on radar display see chapter 5.3. Maximum distance to a ship will normally be about 10 nm and approximately 30nm to a helicopter, dependent on the helicopters altitude. The transponder will not give any alarms further away than this.

The primary alarm will usually be an Emergency Position Indicating Radio Beacon (EPIRB) or distress call on VHF / HF - manual or via digital selcall.

The Tron SART20 should be activated immediately after activation of the EPIRB or by instruction from the rescue control centre.



The batteries of the Tron SART20 will last at least 96 hours in standby after activation and then minimum 8 hours of continuous operation.

Although the transponder does not send any alarm via satellite, VHF or other radio communication, the use should be limited to short tests and emergency situations. This is to save battery capacity in case of a situation where the transponder is needed.

1.2 Tron SART20 features

Watertight:

Tron SART20 is watertight to a depth of minimum 1 meter.

Buoyant:

Tron SART20 is buoyant in case the transponder is accidentally dropped into the water. To increase coverage the SART20 should always be held or mounted as high as possible.

Rugged design:

The Tron SART20 will withstand a drop from 20 meters into the water. It is resistant to seawater, oil and sunlight.

Handling:

Tron SART20 is designed for easy operation, with a brief operating instruction printed on the unit. It comes standard with a 10 meter rope and a shackle hook to be used for hanging the SART20 on the inside of a life raft.

Indicators:

Tron SART20 is equipped with an LED and a built in buzzer to indicate operation. The LED will normally give a flash each 4 seconds to show that the Tron SART20 is activated.

When a search and rescue unit is approaching the buzzer will sound each time the SART20 is hit by the radar. A continuous sound from the buzzer means that the ship or helicopter is close to the Tron SART20 and the radar is hitting the Tron SART20 continuously.

Battery unit.

The battery module is to be replaced every 5 year. A battery expiry label on the Tron SART20 housing displays the expiry date. A new battery comes complete with cable and connector.

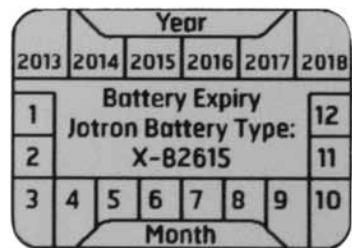

Figure 1.1, Battery expiry label



2 TECHNICAL SPECIFICATIONS

2.1 ELECTRICAL SPECIFICATIONS

Frequency:	X-band (3 cm) (9.2 - 9.5 GHz)
Temperature range:	Operating: -20 to +55°C Storage: -30 to +65°C
Radiated power:	> 400 mW e.i.r.p (+26 dBm)
Sweep type:	12 sweep sawtooth type Forward 7.5 us \pm 1 ms Return 0.4 us \pm 0.1 ms Starts with return sweep.
Receive sensitivity:	Better than -50 dBm e.r.s.
Response delay:	Max 0.5 ms
Antenna pattern:	Horizontal polarization. Omni directional radiation in the horizontal plane. Greater than \pm 12.5 degrees elevation angle in the vertical plane.
Battery:	Lithium metal 7,2V/3600 mAh, 5 years service life.
Battery capacity:	96 hours standby +8 hours continuous operation when activated by a radar with 1 kHz prf at -20°C. 5 years storage.

2.2 MECHANICAL SPECIFICATION

Materials used:	
- Transponder housing:	Glass reinforced polycarbonate
- Bracket:	Anodized aluminum.
Transponder dimensions:	Max diameter: 89 mm Length: 250 mm Weight: 482 g
Transponder with standard storage bracket:	Max diameter: 90 mm Length: 250 mm



3 FUNCTIONAL DESCRIPTION

3.1 GENERAL

Tron SART20 consists of a housing sealed at the lower end with a bottom lid and may be split into the following main parts:

1. Bottom lid.
2. Housing with Tron SART20 electronic assembly and battery module.
The housing is made of glass reinforced polycarbonate.

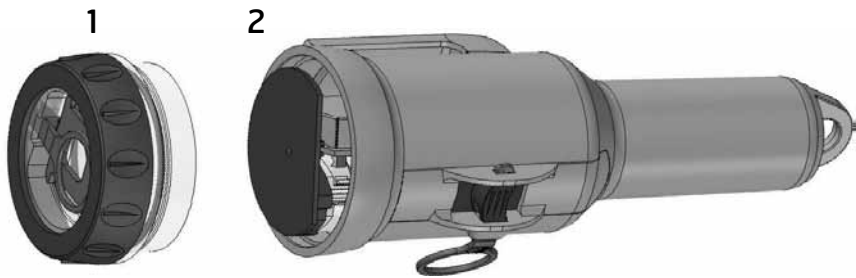

Figure 3.1, Tron SART20 disassembled

3.1.1 TRON SART20 ELECTRONIC ASSEMBLY

Tron SART20 electronic assembly is inserted into the Tron SART20 housing. It consists of the transceiver module and antenna.

1. Transceiver Board in metal box
2. Antenna (9GHz).

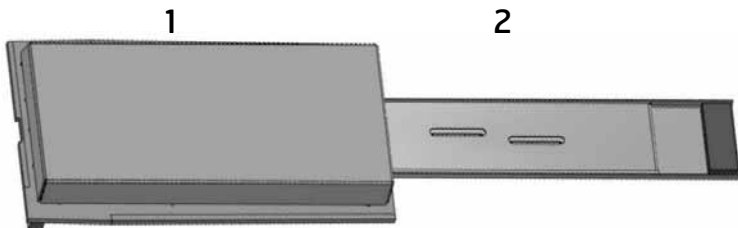

Figure 3.1.1 Tron SART20 electronic assembly

3.1.2 BATTERY MODULE

The battery module is inserted into the Tron SART20 housing.

A battery expiry label on the Tron SART20 housing displays the battery expiry date.

A new battery module comes complete with cable and connector and can be changed by opening the bottom lid of the Tron SART20, see description in chapter 6

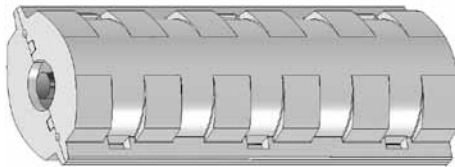

Battery expiry label

Figure 3.1.2 TRON SART20 BATTERY
- module without cable and connector

3.1.3 BOTTOM LID

The Bottom lid includes four items:

1. The winder hook
2. The screw ring
3. The light tower
4. The O-ring

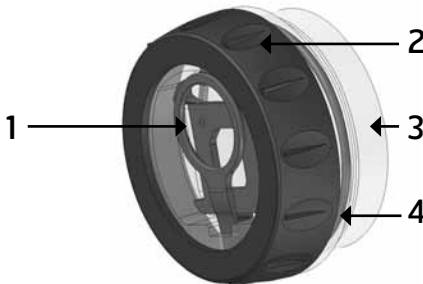

Figure 3.1.3 Bottom lid

4 INSTALLATION

Tron SART20 can be mounted several ways; Near the vessels emergency exit, normally in the wheelhouse at the starboard or port exit (or both, depending of requirements) and inside liferaft or lifeboat. (See "GMDSS requirements in chapter 1.

4.1 BRACKETS

There are 3 different mounting brackets available.

1. Wall bracket
2. Lifeboat bracket (optional)
3. Pole (optional)

4.1.1 WALL BRACKET

A wall bracket is delivered with the Tron SART20 and should be used for storage of the transponder. The bracket should preferably be mounted in a vertical position and in a place where the Tron SART20 is easily available in case of an emergency.

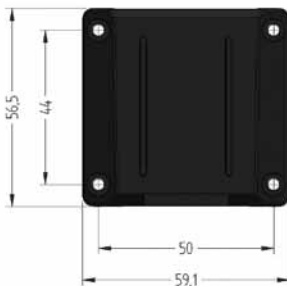

Figure 4.1.1a, wall bracket.



Figure 4.1.1b, Tron SART20 mounted in wall bracket.

The bracket should be mounted with four screws (\varnothing 4 mm).

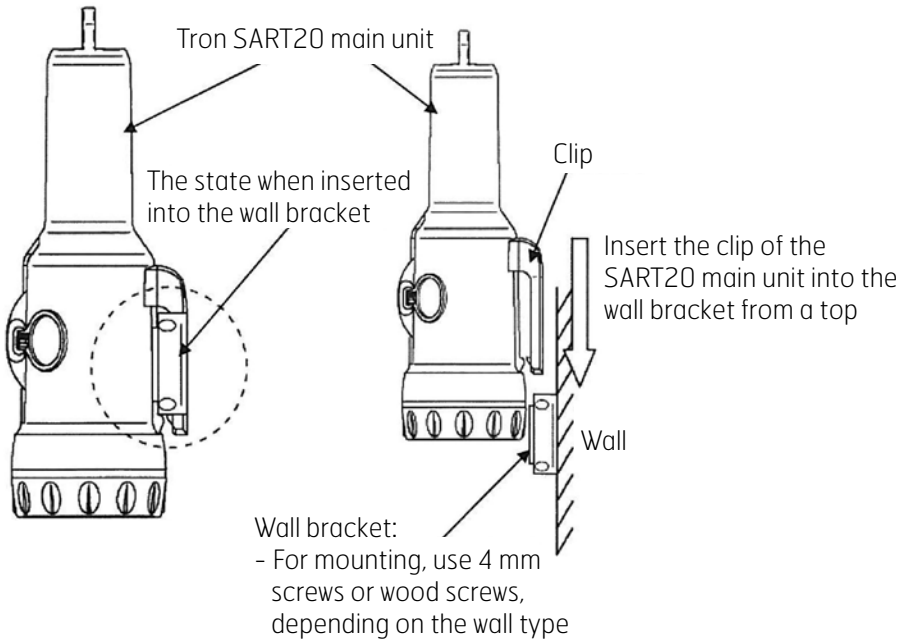

Figure 4.1.1c, Installation diagram of the SART20 main unit and the wall bracket

4.1.2 LIFEBOAT BRACKET (optional)

The outdoor lifeboat bracket should be mounted vertically on the roof of the lifeboat (as high as possible). Tron SART20 shall not be permanently stored in this bracket if mounted outside a freefall lifeboat, but moved to this bracket after lifeboat is deployed in water.

Activate the transponder and put it into the bracket. Secure the transponder to the bracket. The bracket will fit a pipe with a maximum diameter of 50mm.

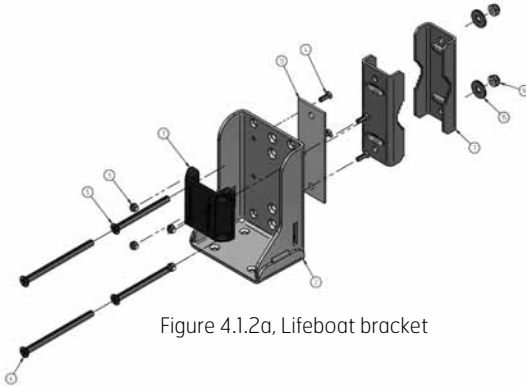

Figure 4.1.2a, Lifeboat bracket

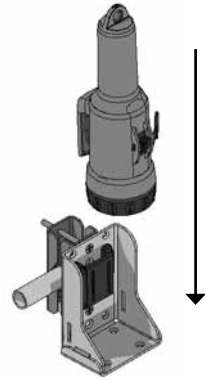

Figure 4.1.2b, Tron SART20 to put into lifeboat bracket

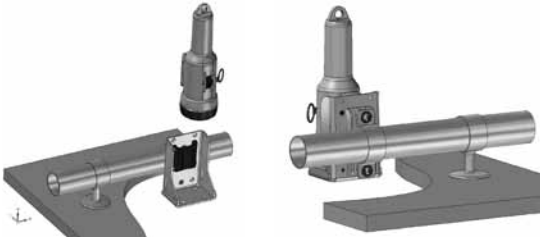

Figure 4.1.2c, Examples of pipe mounting

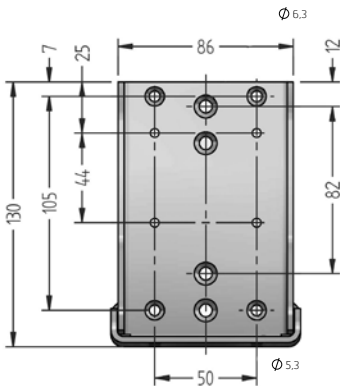

Figure 4.1.2d, Tron SART20 lifeboat bracket

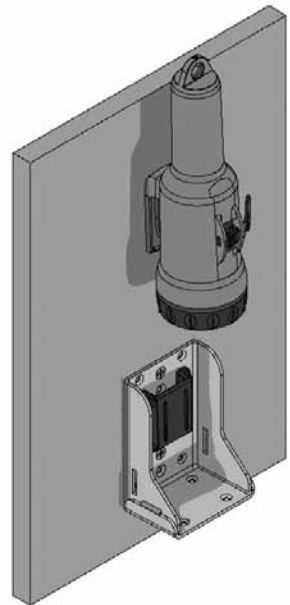

Figure 4.1.2e Example of Mounting the Bracket on Interior and Exterior Walls of a Lifeboat



4.1.3 USING THE TELESCOPIC POLE



Figure 4.1.3 Tron SART20 with telescopic pole attached.

A telescopic pole can be used to extend the height of the Tron SART20, inside or outside the life raft/boat. Simply extend the attached pole to the full length (app. 1,2m from the top of the Tron SART20). Make sure that the rod is locked by pulling hard when it is fully extended. The rod can now be fastened or held by a person. Ensure the rod is held as vertical as possible when activating the Tron SART20.

May be used for mounting inside a liferaft (optional).



5 OPERATION

Tron SART20 should be installed according to chapter 1 and 4, and in a distress situation, the Tron SART20 should be carried from it's storage position to the liferaft/lifeboat

5.1 ACTIVATING TRON SART20

1. Break seal at switch.
2. Pull locking pin and make sure that the switch enters the "ON" position. An audible "BEEP" will be heard and the indicator led will start to flash every 4 sec
3. Place (or hold) the transponder in a vertical position as high as possible.
When the Tron SART20 is within range of an active 3 cm radar x-band, the internal loudspeaker will be activated. A handheld VHF radio should now be used to establish contact with the approaching boat or helicopter.

After activating the Tron SART20, it shall be mounted in lifeboat/liferaft as described in ch. 5.3.

5.1.1 DEACTIVATING TRON SART20

1. Move the switch to the "OFF" position.
2. Replace the locking pin.

5.2 EXAMPLES OF USAGE IN LIFEBOAT/LIFERAFT



Figure 5.2.1. How to mount Tron SART20 to a life raft



www.jotron.com

From figure 5.2.1 above, left to right:

1. Using "life raft mounting strap" (or optionally the 10m lanyard)
2. SART pocket
3. Pole

5.2.1 SART POCKET

There are different ways of mounting a Tron SART20 in an inflatable Life Raft:

It is often a SART pocket where the Tron SART20 may be lifted to the canopy after deploying the raft (See figure 5.2.1, middle)

- Put the SART20 into the SART pocket.
- Lift the pocket by it's rope to the canopy

5.2.2 LIFE RAFT MOUNTING STRAP

We can supply a "SART Life-raft mounting strap" (partno. 85120) as seen on the attached pictures to be mounted to the inflatable canopy.



- Attach the strap as seen on picture above
- Fasten the other end to the canopy as seen on figure 5.2.1

5.2.3 SART POLE MOUNTING

You may use the 1m Pole arrangement (partno. 82900) (See figure 5.2.1, right)

- Attach the pole to SART20
- Extend the pole to it's full length and make sure it is "locked"
- Lift it up through the tent airtube (if available) and secure using the liferafts mounting for SART pole (strap, rope etc.)



www.jotron.com

5.2.4 10 M REEL WITH LANYARD

The last solution is to use the 10m lanyard (see figure 5.2.1, left) and picture below.



- Remove the lanyard reel as seen on picture above
- Roll out the lanyard from the reel
- Thread it through the fastening ring of the top of the SART20
- Lift SART20 to the canopy and fasten as seen on figure 5.2.1, left







5.3 TEST OF TRON SART20

Test of the Tron SART20 is done using the ships own 3 cm X-band radar. The radar display will show different patterns depending on the range to the transponder. See Figure 5.3a, b and c for details of the radar display. Note that the examples shown are typical and will vary with the radar performance (height, power output and sensitivity).

With the transponder located close to the radar the signals will appear as rings on the radar display. The rings may be broken in some sectors, depending on ship construction and other obstacles, and does not indicate an error in the transponder. Placing it further away will reduce the signals to 12 dots on the radar display, showing the direction to the transponder.

Modern radars often have special function that will optimize reception of radar SART, either in TEST or ON. If the Radar has such function, the Radar is detuned out of best tuning condition, and erases or weakens all normal radar echoes, but SART echoes are not erased because SART frequencies scans over all the X-band from 9.2 to 9.5 GHz. When this function is selected on the radar, a text "SART" is shown at the bottom of the display.

Note! Make sure that the SART feature is turned off when SART detection is no longer necessary

1. Hold the switch on the Tron SART20 in the "TEST" position.
2. Simultaneously a person should observe the radar display to check for correct pattern. The radar should be set for a 10 nm range.
3. The test should preferably be done in open sea to avoid interference on the radar display from land echoes.
4. Alternatively, a radar of a nearby ship can be used to test the transponder. A ship to ship VHF channel should then be used to confirm operation.

Figure 5.3a
Typical display when Tron SART20 is located near (<0.2 nm) the radar. Radar range is 10 nm. Rings are off.

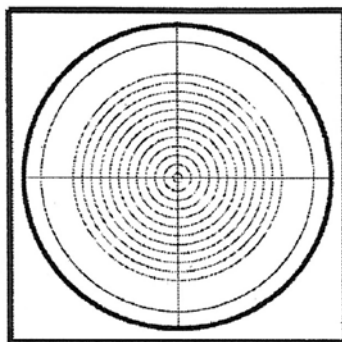

Figure 5.3.b Typical display when Tron SART20 is located close (1nm) to the radar. Radar range is 10 nm. Rings are at 2 nm.

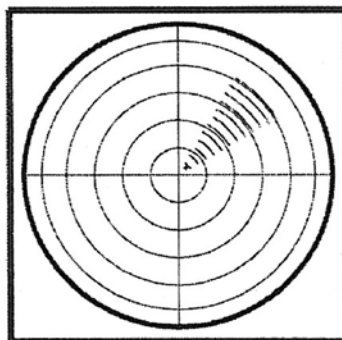
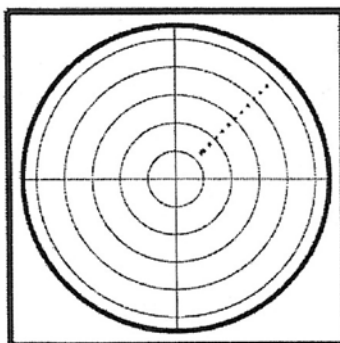

Figure 5.3c Typical display when Tron SART20 is located away (>2 nm) from the radar. Radar range is 10 nm. Rings are at 2 nm.





CAUTION!

While the Tron SART20 is activated it will respond to any 3 cm radars within range. Tests must be made as short as possible (5 min) to avoid interference and to avoid wasting battery capacity.

6 MAINTENANCE AND TROUBLESHOOTING

6.1 MAINTENANCE

Tron SART20 requires the following maintenance:

At least every 6. month.

The transponder should be taken out of its bracket and tested against a radar, using the procedure in chapter 5.3. Either the ships own radar could be used or the radar of a nearby ship. Note that the self test use the internal battery and will reduce the operational lifetime of the equipment - therefore the test should be limited to not more than once every month.

Every 5. year.

The battery unit must be replaced every 5 year. Storage of batteries over a long period of time will reduce their capacity. To ensure long and reliable operation the battery unit must be replaced every 5 year. The battery replacement can be performed on board using the procedure in chapter 6.2.1.

6.2 SERVICE

Warranty Service

All goods sold by the Company are warranted to be free from defect in workmanship and material for the period of five (5) years from the date of purchase from Jotron. For further information, see pos.6 "Guarantee" in our Terms and Conditions of Sale.

Provided that the unit(s) returned for repair is under warranty, man-hour cost and material cost will be covered by Jotron. This is not valid if the customer has tried to repair, modify or rebuild the unit, or if the unit has been exposed to environmental conditions outside the specifications for the unit. If the unit is in need of repair, please return it carriage paid to the agent that you purchased it from. Additional costs not related to repair/replacement of the unit will not be covered.



www.jotron.com

Out of Warranty Service

For defects arising from normal wear and tear after 12 months of operation, limited to 18 months from Jotron AS, normal service conditions will apply. For details see: www.jotron.com

6.2.1 REPLACING THE BATTERY MODULE

Below is a description on how to change batteries on AIS-SART

Dissassembly:



Twist the rubber grip anti-clockwise to remove the lid



It might be difficult to remove the lid. If so, remove the rubber grip first



And then twist off the lid



Opened



Rubber holder below battery and electronics removed



Pull out the battery



Pull out the cable from connector



Remove old Silaca gel bags

See these pictures in colours on www.jotron.com



www.jotron.com

Assembly:



Install the new battery. Make sure the cable is within the guide



Connect cable to electronics, black= left, red= right



Add 2x5 g Silica gel bags



Mount rubber holder



Remove old O-ring using a Credit Card



Use acid-free Vaseline on the new O-ring



Fit the new O-ring



Reinstall lid- tighten without tools



Replace the rubber grip



Assembly completed

See these pictures in colours on www.jotron.com



6.2.2 BATTERY DISPOSAL

Dispose in accordance with applicable regulations, which vary from country to country. (In most countries, the disposal of used batteries is regulated and end-users are invited to dispose of them correctly, through non-profit organizations, mandated by local governments or organized on a voluntary basis by professionals). Lithium batteries should have their terminals insulated prior to disposal.

6.2.3 INCINERATION

Incineration should never be performed by battery users but by trained professionals in authorized facilities with proper gas and fumes treatment.

6.2.4 LAND FILLING

Leachability regulations (mg/l)

Component	Leachability	EC limit	EPA	Other*
Iron	100	500	2	5
Nickel	100			0,5

* Applicable to France

6.2.5 RECYCLING

Send to authorized recycling facilities, through a licensed waste carrier.

7 SPARE PARTS/ACCESSORIES

- 83010 Tron SART20 Main unit
- 84065 Lifeboat bracket
- 82900 Pole bracket
- 82120 Life raft mounting strap
- 82615 Battery, Tron SART20, 5 years maintenance kit
- 82746 Bulkhead bracket



www.jotron.com

8 SERVICE AGENTS

Please look at www.jotron.com for Marine Service Agents.

Jotron Group subsidiary companies:

Jotron UK Ltd.

Crosland Park
Cramlington
NE23 1LA
United Kingdom
Tel +44 1670 712000
Fax +44 1670 590265
E-mail: sales@jotron.com

Jotron Asia Pte. Ltd.

Changi Logistics Center
19 Loyang Way #04-26
Singapore 508724
Tel +65 65426350
Fax +65 65429415
E-mail: sales@jotron.com

Jotron USA, Inc.

10645 Richmond Avenue, Suite 170
Houston, TX 77042
USA
Tel +1 713 268 1061
Fax +1 713 268 1062
E-mail: sales@jotron.com



Jotron AS
Jotron UK Ltd.
Jotron Phontech AS
Jotron Consultas AS
Jotron Asia Pte. Ltd.
Jotron USA, Inc.
UAB Jotron



www.jotron.com